

- Orden de arranque remoto
- Petición de CO2
- Motor en marcha
- Motor acoplado
- Permiso recup. gases
- Demanda de CO2
- Permiso uso CO2
- Alarma cuadro CodINDe SER
- Alta Tª antes de catalizador
- Alta Tª después de catalizador

**GAS**

M PID 0.00 0.00

**G1**

0 kW 0 VAr 0.000 PF

**HT**

14.6 14.6

**LT**

0.0 0.0

**Acete Usado**

**Acete Limpio**

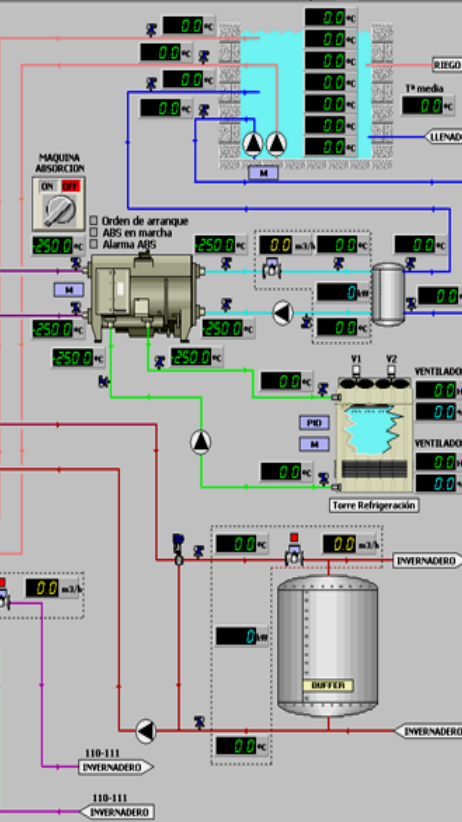
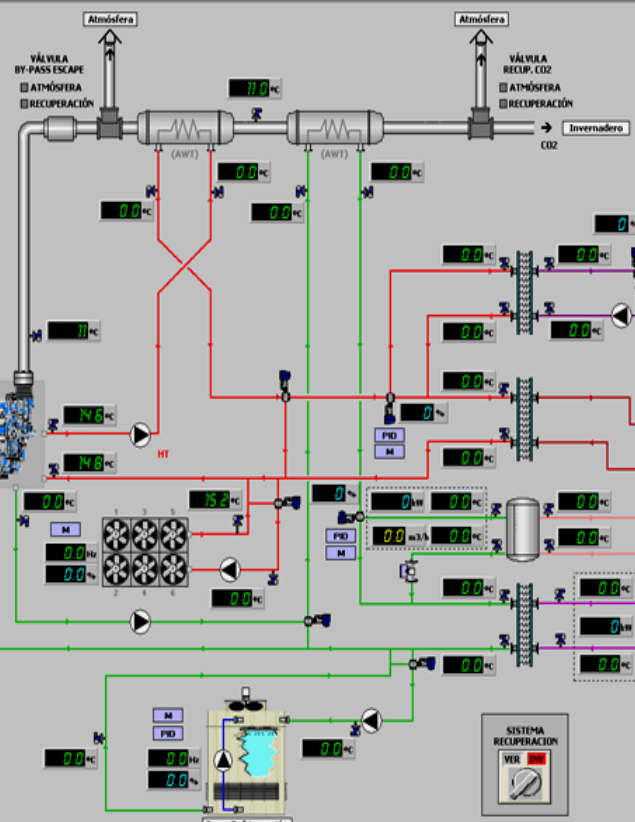



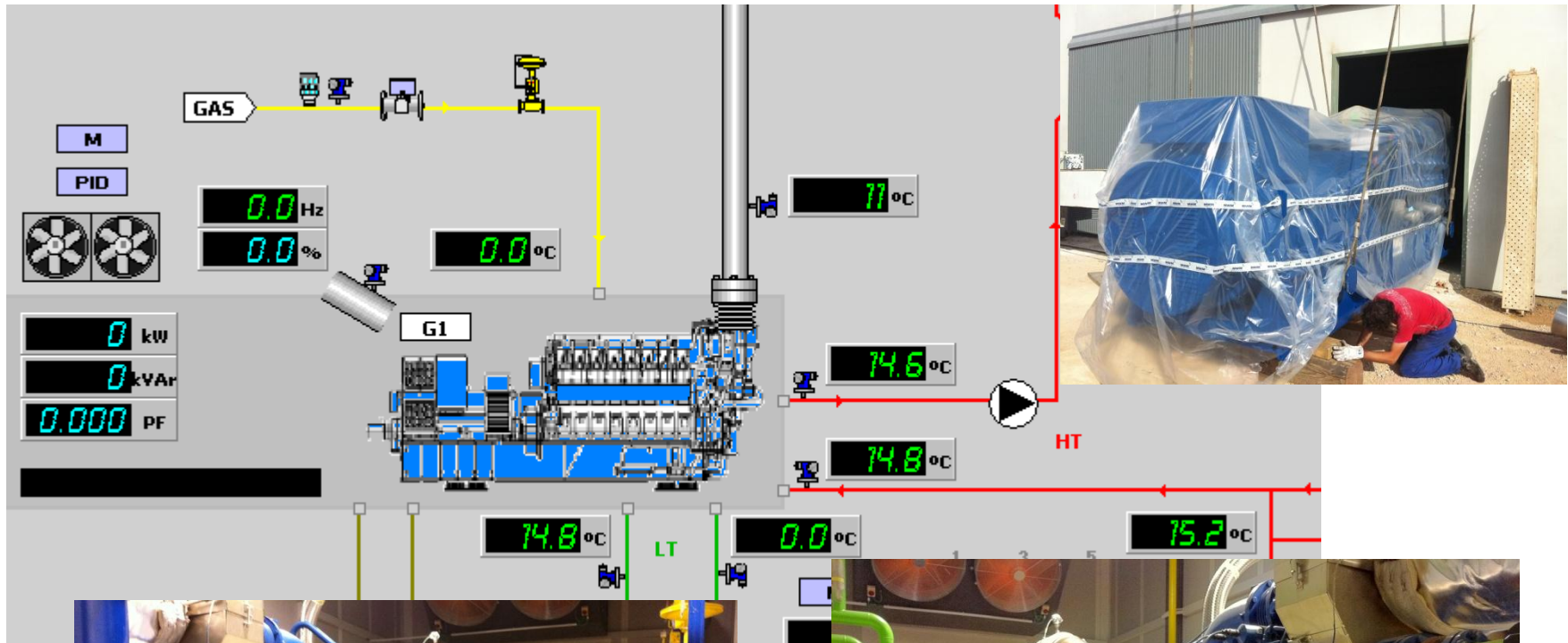

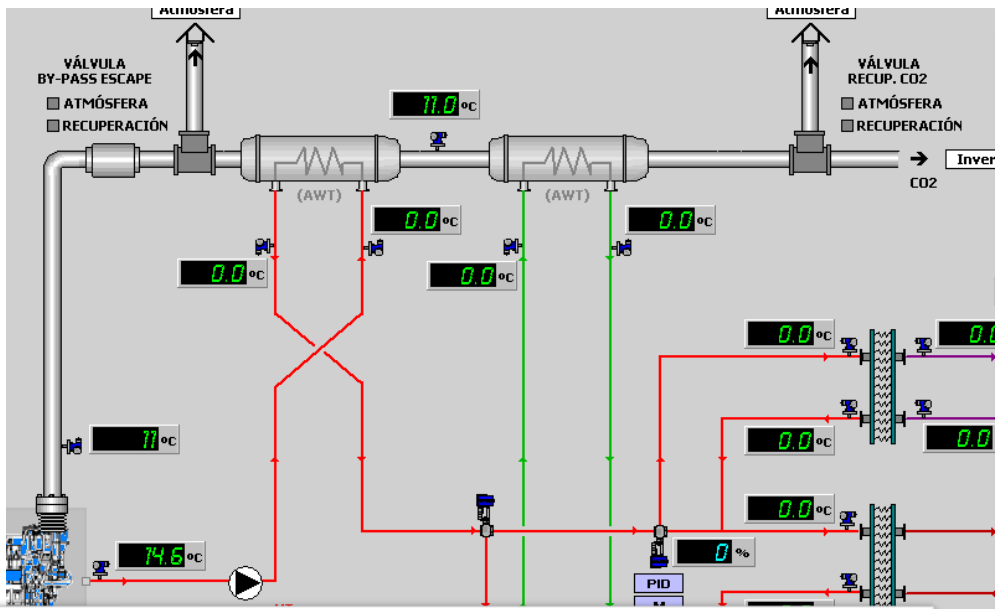



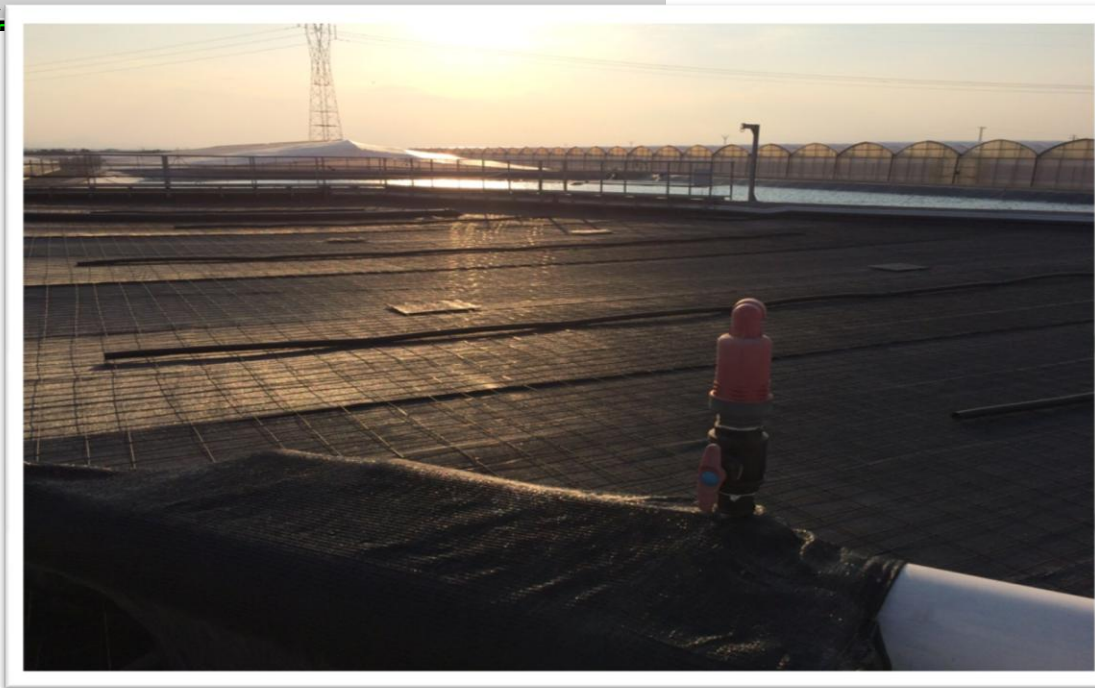
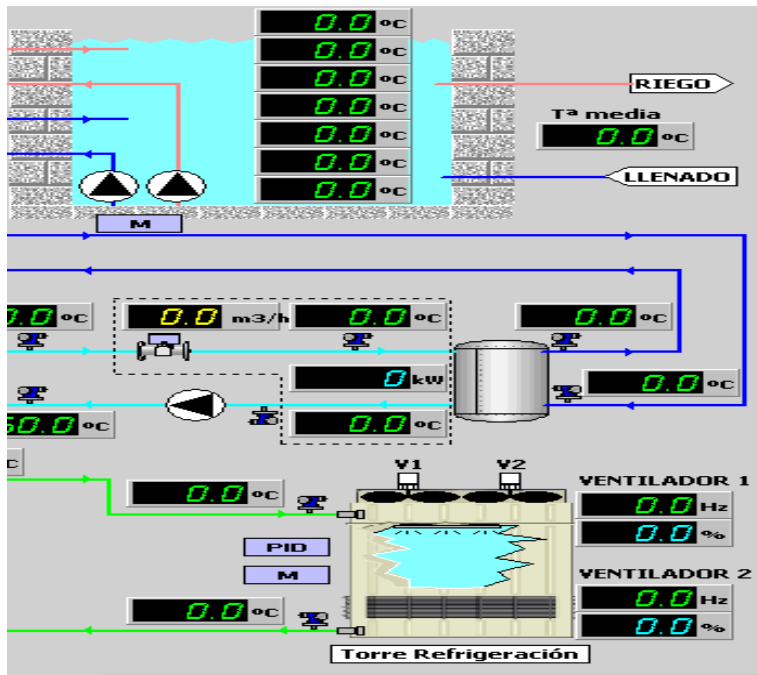



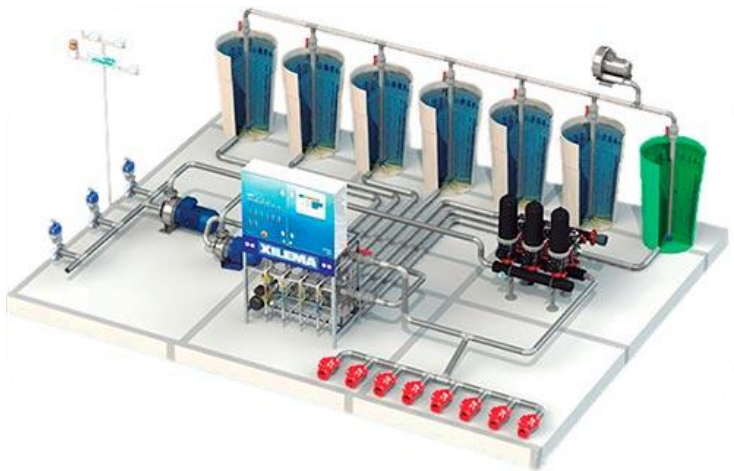

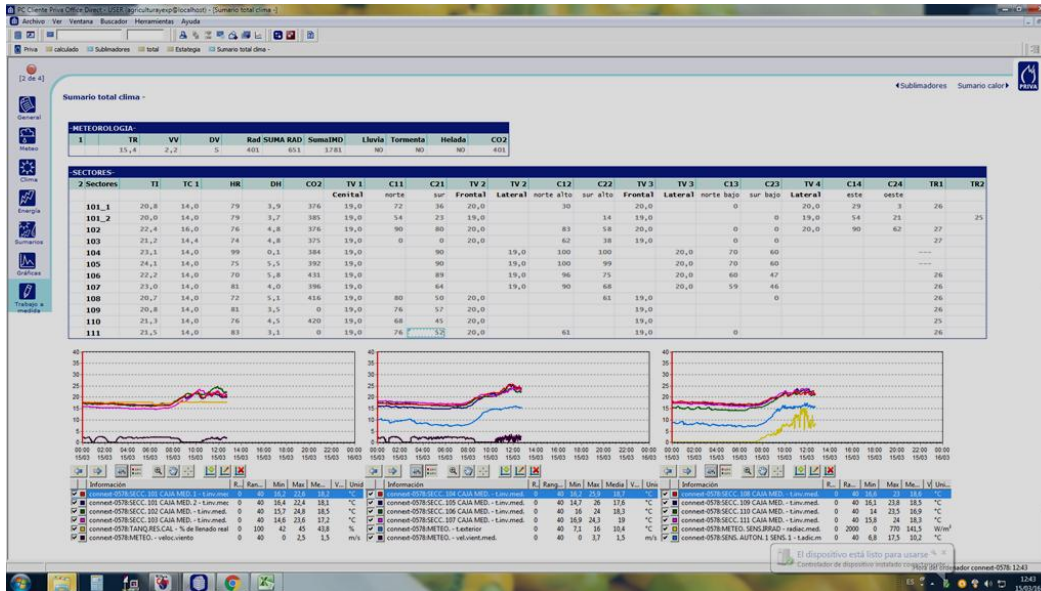
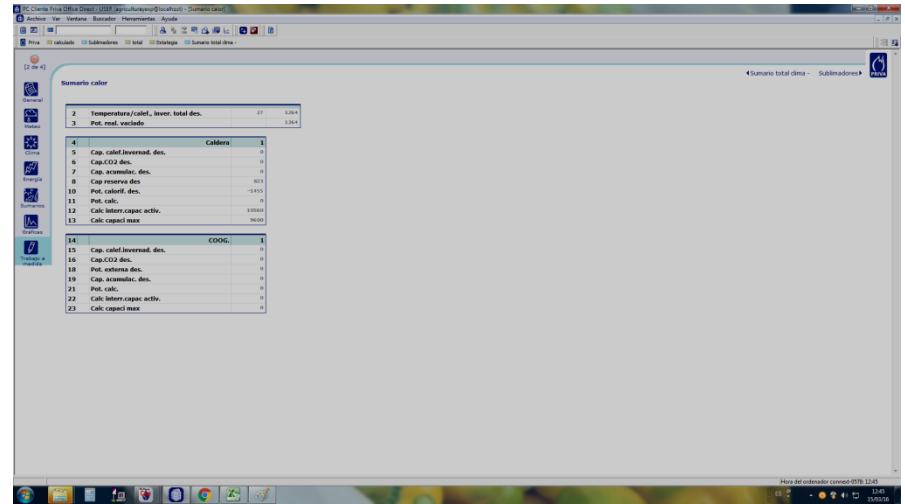

Finalmente, gracias a esta apuesta por la mejora tecnológica combinada con el aprovechamiento máximo de los recursos a nuestra disposición, las necesidades hídricas actuales por m<sup>2</sup> de invernadero son de **9250,5m<sup>3</sup> por Hectárea y año.**



**Muchas gracias por la  
atención prestada**